

Features

- 60 V_{DC}/6 A Half-Bridge Driver
- 14 mΩ (typ), integrated high side and low-side eGaN FETs
- Integrated GaN gate driver and level-shifter
- 12 V external bias supply
- 3.3 V or 5 V CMOS input logic levels
- Independent high side and low side control inputs
- Logic Input Shoot-Through Protection, commands both FETs off when control inputs are both high at same time
- Internal Under-Voltage Lockout (UVLO) Circuitry
- Synchronous charging for high side bootstrap supply
- Flexible power-sequencing with active gate pull-down for HS and LS FET allows for V_{IN} before V_{Bias} power-up
- High Speed Switching Capability: 2+ MHz
- Compact AlN Ceramic SMT Package (L7)
 - Improved Thermal Conductivity Over Al₂O₃
- Total Ionizing Dose:
 - Rated to 1000 kRad
- Single Event:
 - SEE immunity for LET of 63 MeV/mg/cm² with V_{DD} up to 100% of Rated Voltage
- Neutron Fluence:
 - Maintains specification up to 1 x 10¹⁵ N/cm²



EPC7012L7SH

60 V_{DC}/6 A Radiation-Hardened GaN Power Stage

Description

The EPC Space EPC7012L7SH, is a radiation-hardened, half-bridge GaN power stage. Input logic interface, level shifting, bootstrap charging and gate drive buffer circuits along with eGaN output FETs configured as a half-bridge, are integrated within a monolithic chip in a custom 7-pin Aluminum Nitride SMT ceramic package. Datasheet parameters are “Post Radiation Effects.” 60 V_{DC} is derated from 80 V_{DC}.

Applications

- Single and Multi-Phase Motor Drivers:
 - Reaction Wheel Assemblies (RWAs)
 - Momentum Wheels
 - Robotic Actuators
- Half-Bridge/POL Power Supplies:
 - Low Current Single Phase
 - High Current Multi-Phase
- Satellite Electrical Power System

EPC7012L7SH Functional Block Diagram

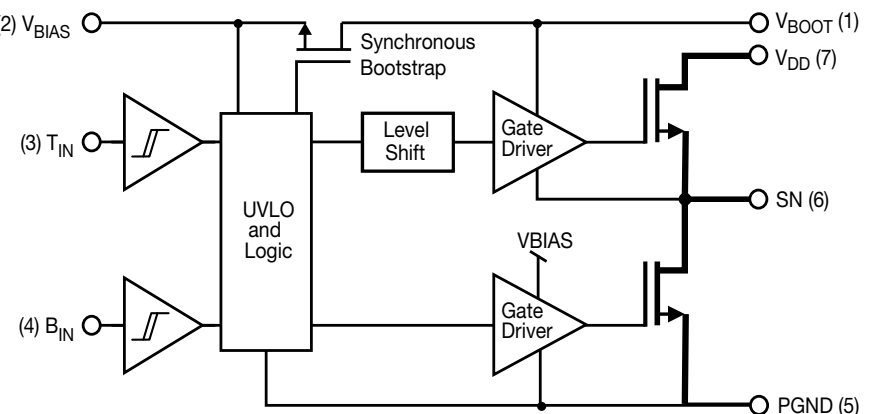

7-Pin AIN Ceramic SMT Package

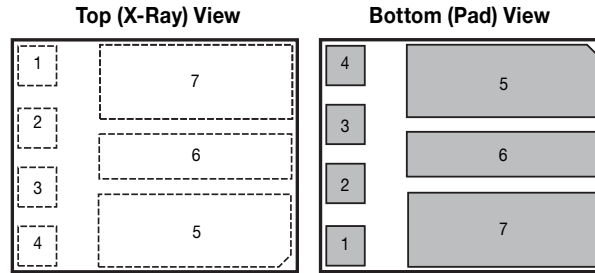

EPC7012L7SH Configuration and Pin Assignment Table

Pin	Pin Name	Input/Output	Pin Function
1	V _{BOOT}	P/I	High-Side Driver Floating Power Supply
2	V _{BIAS}	P/I	+12 V _{DC} , Nominal, Gate Driver Power Supply Bias Input Voltage
3	T _{IN}	L/I	High-Side Switch Logic Input
4	B _{IN}	L/I	Low-Side Switch Logic Input
5	PGND	H	Power Supply Return, 0 V _{DC} (High Current)
6	SN	P/O/H	Switching Node (High dV/dt, High Current)
7	V _{DD}	P/I/H	Positive Power Supply Input (High Current)

KEY: P = Power, L= Logic, I= Input, O = Output, H = High Current Connection, GR = Ground Return

Pin Descriptions

V_{BOOT} (Pin 1)

High-Side Driver Floating Power Supply. The floating bootstrap high-side driver power supply referenced to the SN output (pin 6). For proper operation, connect an external bootstrap capacitor (0.1 μF recommended) from V_{BOOT} to SN.

V_{BIAS} (Pin 2)

The raw DC bias power supply referenced to GND that supplies power to the low-and high-side gate drivers and to the internal logic in the EPC7012L7SH. Connect two external bypass capacitors (0.1 μF and 10 μF recommended) from V_{BOOT} to PGND (Pin 7).

T_{IN} (Pin 3)

The T_{IN} pin is the logic input for high-side power driver. When the T_{IN} input pin is logic low (“0”), the high-side output (V_{DD}-SN) pins (pins 5 and 6) are in the OFF (high impedance) state. When the T_{IN} input pin is logic high (“1”), the V_{DD}-SN pins are in the ON (low impedance) state.

B_{IN} (Pin 4)

The B_{IN} pin is the logic input for low-side power driver. When the B_{IN} input pin is logic low (“0”), the low-side output (SN-PGND) pins (pins 6 and 7) are in the OFF (high impedance) state. When the B_{IN} input pin is logic high (“1”), the SN-PGND pins are in the ON (low impedance) state.

PGND (Power Ground) (Pin 5)

The PGND pin (pin 7) is the ground return connection for the internal power output circuitry and high-speed gate driver circuitry associated with low-side power driver and for the power good and interface logic for the high-side driver. This pin should be connected directly to the system power return/ground plane to minimize common source inductance, and the voltage transients associated with this inductance. This is a high-current connection.

SN (Switching Node) (Pin 6)

The SN pin (pin 6) is the high-current power output for the half-bridge driver. This output alternates from high impedance (the low- and high-side power switches OFF when both logic inputs are “0” or “1” simultaneously) to low impedance from the SN pin to PGND (when B_{IN} is logic “1”) to low impedance from the V_{DD} pin (pin 5) to SN (when T_{IN} is logic “1”). This is a high-current connection.

V_{DD} (Pin 7)

The V_{DD} pin (pin 5) is the high-current reference potential for the high-side power driver. This pin should be connected directly to the system power (V_{DD}) bus via a low impedance connection, preferably through a low impedance power plane. This pin should be properly bypassed to the system power ground (PGND, pin 7) using the guidelines found in the “Recommended V_{DD}-to-PGND Power Supply Bypassing” section, following. This is a high-current connection.

Absolute Maximum Rating ($-55^{\circ}\text{C} \leq T_{\text{C}} \leq 125^{\circ}\text{C}$ unless otherwise)

Symbol	Parameter-Conditions	Value	Units
V_{DD}	Positive Power Supply Input Voltage (Note 1)	60	V
I_{DD}	Continuous Operating Current	6	A
V_{BIAS}	Continuous Gate Driver Bias Supply Voltage	14.0	V
V_{BOOT}	Continuous Bootstrap Supply Voltage	14.0	
$B_{\text{IN}}, T_{\text{IN}}$	B_{IN} or T_{IN} Logic Input Voltage	-0.3 to 5.5	$^{\circ}\text{C}$
T_{STG}	Storage Junction Temperature Range	-55 to +150	
T_{J}	Operating Junction Temperature Range	-40 to +125	
T_{C}	Case Operating Temperature Range	-55 to +125	
T_{sol}	Package Mounting Surface Temperature	230	
ESD	ESD class level (HBM)	1B	
	Device Weight	0.226	g

Thermal Characteristics

Symbol	Parameter-Conditions	Value	Units
$R_{\theta\text{JA}}$	Thermal Resistance Junction to Ambient	55	$^{\circ}\text{C}/\text{W}$
$R_{\theta\text{JLid}}$	Thermal Resistance Junction to Case: Lid/Top	5.1	
$R_{\theta\text{JC}}$	Thermal Resistance Junction to Case: Bottom of the Pads	2.5	

Low- and High-Side Power Switch Static Electrical Characteristics

Symbol	Parameter	Test Conditions	MIN	TYP	MAX	Units
I_{DSS}	Drain - Source Leakage Current (V_{DD} -to-SN or SN-to-PGND) (Note 2)	$V_{\text{DS}} = 48 V_{\text{DC}}$; $B_{\text{IN}} = T_{\text{IN}} = 0.8 V_{\text{DC}}$	$T_{\text{C}} = 25^{\circ}\text{C}$	2	200	μA
			$T_{\text{C}} = 125^{\circ}\text{C}$	8	200	
		$V_{\text{DS}} = 60 V_{\text{DC}}$; $B_{\text{IN}} = T_{\text{IN}} = 0.8 V_{\text{DC}}$	$T_{\text{C}} = 25^{\circ}\text{C}$	3	200	
			$T_{\text{C}} = 125^{\circ}\text{C}$	9	200	
$R_{\text{DS(on)}}$	Drain - Source ON-State Resistance (V_{DD} -to-SN or SN-to-PGND) (Notes 3, 4, 5)	$I_{\text{D}} = 3 \text{ A}$ $B_{\text{IN}} = 2.4 V_{\text{DC}}$ or $T_{\text{IN}} = 2.4 V_{\text{DC}}$	$T_{\text{C}} = 25^{\circ}\text{C}$	14	19	$\text{m}\Omega$
			$T_{\text{C}} = 125^{\circ}\text{C}$	20	22	
			$T_{\text{C}} = -55^{\circ}\text{C}$	9	16	
		$I_{\text{D}} = 6 \text{ A}$ $B_{\text{IN}} = 2.4 V_{\text{DC}}$ or $T_{\text{IN}} = 2.4 V_{\text{DC}}$	$T_{\text{C}} = 25^{\circ}\text{C}$	14	19	
			$T_{\text{C}} = 125^{\circ}\text{C}$	20	22	
			$T_{\text{C}} = -55^{\circ}\text{C}$	9	16	
V_{SD}	Source-Drain Clamping Voltage (SN-to- V_{DD} or PGND-to-SN) (Notes 5, 6, 7)	$I_{\text{D}} = -3 \text{ A}$ $B_{\text{IN}} = T_{\text{IN}} = 0.8 V_{\text{DC}}$	$T_{\text{C}} = 25^{\circ}\text{C}$	2.4	3	V
			$T_{\text{C}} = 125^{\circ}\text{C}$	2.4	4	
			$T_{\text{C}} = -55^{\circ}\text{C}$	2.4	3	
		$I_{\text{D}} = -6 \text{ A}$ $B_{\text{IN}} = T_{\text{IN}} = 0.8 V_{\text{DC}}$	$T_{\text{C}} = 25^{\circ}\text{C}$	2.4	3	
			$T_{\text{C}} = 125^{\circ}\text{C}$	2.4	4	
			$T_{\text{C}} = -55^{\circ}\text{C}$	2.4	3	

Recommended Operating Conditions ($-55^{\circ}\text{C} \leq T_C \leq 125^{\circ}\text{C}$ unless otherwise noted)

Symbol	Parameter-Conditions	Value	Units
V_{DD}	Positive Power Supply Input Voltage (Note 1)	60	V
I_{DD}	Continuous Operating Current	5	A
V_{BIAS}	Continuous Gate Driver Bias Supply Voltage	11 - 13	V
V_{BOOT}	Continuous Bootstrap Supply Voltage	11 - 13	

 B_{IN} , T_{IN} Logic Input Static Electrical Characteristics ($-55^{\circ}\text{C} \leq T_C \leq 125^{\circ}\text{C}$ unless otherwise noted)

Symbol	Parameter	Test Conditions	MIN	TYP	MAX	Units
V_{IL}	Low Logic Level Input Voltage	$V_{BIAS} = 12 V_{DC}$ (Note 8)			0.8	V
V_{IH}	High Logic Level Input Voltage	$V_{BIAS} = 12 V_{DC}$ (Note 8, 9)	2.4			
V_{HYST}	Input Logic Threshold Hysteresis	$V_{BIAS} = 12 V_{DC}$ (Note 10)	0.3	0.4	0.7	
R_{IL}	Logic Input Pull-Down Resistance	$V_{BIAS} = 12 V_{DC}$, $V_I = 5.0 V_{DC}$		10		

 V_{BIAS} and V_{BOOT} Electrical Characteristics ($-55^{\circ}\text{C} \leq T_C \leq 125^{\circ}\text{C}$ unless otherwise noted)

Symbol	Parameter	Test Conditions	MIN	TYP	MAX	Units
I_{BIAS}	V_{BIAS} Quiescent Operating Current	$V_{BIAS} = 12 V_{DC}$, $B_{IN} = T_{IN} = 0.8 V_{DC}$		22	25	mA
	V_{BIAS} Operating Current, $f_s = 1$ MHz	$V_{BIAS} = 12 V_{DC}$, $B_{IN} D/C = T_{IN} D/C = 50\%$		32	45	
I_{BOOT}	V_{BOOT} Quiescent Operating Current	$(V_{BOOT} - V_{SN}) = 12 V_{DC}$, $T_{IN} = 0.8 V_{DC}$		8	11	
	V_{BOOT} Operating Current, $f_s = 1$ MHz	$(V_{BOOT} - V_{SN}) = 12 V_{DC}$, $T_{IN} D/C = 50\%$		13	16	
V_{SYNC}	V_{BOOT} -to- V_{SN} Operating Voltage	$(V_{BOOT} - V_{SN}) = 12 V_{DC}$	9	11.5	13	V

Under-Voltage Lockout Static Electrical Characteristics ($-55^{\circ}\text{C} \leq T_C \leq 125^{\circ}\text{C}$ unless otherwise noted)

Symbol	Parameter	Test Conditions	MIN	TYP	MAX	Units
$V_{BIAS} UVLO+$	$V_{BIAS} UVLO$ Rising Threshold	(Note 11)	5.5	9	10.9	V
$V_{BIAS} UVLO (HYST)$	$V_{BIAS} UVLO$ Falling Hysteresis			0.6		
$V_{BOOT} UVLO+$	$V_{BOOT} UVLO$ Rising Threshold	(Note 12)	5.5	9	10.9	
$V_{BOOT} UVLO (HYST)$	$V_{BOOT} UVLO$ Falling Hysteresis			0.8		

Low- and High-Side Power Switch Dynamic Electrical Characteristics ($T_C = 25^{\circ}\text{C}$ unless otherwise noted)

Symbol	Parameter	Test Conditions	MIN	TYP	MAX	Units
$t_{d(on)}$	B_{IN} -to- SN Turn-ON Delay Time	$V_{DS} = 25 V_{DC}$; $I_O = 6$ A (See Switching Figures)		20	45	ns
$t_{d(off)}$	B_{IN} -to- SN Turn-OFF Delay Time			20	45	
$t_{d(on)}$	T_{IN} -to- SN Turn-ON Delay Time			20	45	
$t_{d(off)}$	T_{IN} -to- SN Turn-OFF Delay Time			20	45	
t_r/t_f	SN Rise/Fall Times			3		
t_{r1}/t_{f1}	Logic Input Rise/Fall Time	From V_{IL} to V_{IH} or V_{IH} to V_{IL} (Notes 6,15)			25	
PW	Minimum B_{IN}/T_{IN} Pulse Width			20		
$t_{(delay)}$	B_{IN} -to- T_{IN} or T_{IN} -to- B_{IN} Dead (Delay) Time	(Notes 6, 13, 14)	20			
D/C	High-Side Power Switch Duty Cycle				95	%
t_{prg}	High-Side Bootstrap Capacitor Pre-Charge Time			5		μs
C_{OSS}	High Side Output Capacitance (V_{DD} - SN)	$V = 5$ V (Notes 6)		625		pF
	High Side Output Capacitance (V_{DD} - SN)	$V = 48$ V (Notes 6)		250		
	Low Side Output Capacitance (SN - $PGND$)	$V = 5$ V (Notes 6)		625		
	Low Side Output Capacitance (SN - $PGND$)	$V = 48$ V (Notes 6)		250		

Notes

- 1) DC value of V_{DD} plus any transient voltage spikes not to exceed this value.
- 2) When either logic input (B_{IN} or T_{IN}) is at the low input voltage level, the associated output switch is guaranteed to be OFF (high impedance).
- 3) When either logic input (B_{IN} or T_{IN}) is at the high input voltage level the associated output switch is guaranteed to be ON (low impedance).
- 4) Measured using current pulse.
- 5) Measured using 4-Wire (Kelvin) sensing techniques.
- 6) Guaranteed by design. Not tested in production.
- 7) Measured using 50 ns current pulse.
- 8) Either B_{IN} or T_{IN} logic input.
- 9) The input shoot-through protection is activated if both the B_{IN} and T_{IN} logic inputs are set to the logic high ("1") condition simultaneously. In the case where the B_{IN} and T_{IN} inputs are set to logic high, both the low- and high-side power switches are set to their high impedance (OFF) state.
- 10) The logic threshold hysteresis is the voltage increment above V_{IF} where the associated output switch is guaranteed to be OFF or the voltage increment below V_{IR} where the associated output switch is guaranteed to be ON, for either logic input.
- 11) Rising V_{BIAS} levels below the V_{BIAS} UVLO+ threshold and falling V_{BIAS} levels below the V_{BIAS} UVLO+ - V_{BIAS} UVLO (HYST) threshold result in the internal low-side gate drivers being disabled and the corresponding output being set to its high- impedance state, regardless of the state of the logic input.
- 12) Rising V_{BOOT} levels below the V_{BOOT} UVLO+ threshold and falling V_{BOOT} levels below the V_{BOOT} UVLO+ - V_{BOOTS} UVLO (HYST) threshold result in the internal high-side gate drivers being disabled and the corresponding output being set to its high- impedance state, regardless of the state of the logic input.
- 13) The high-side power switch gate driver utilizes a bootstrap capacitor to provide the proper bias for this circuit. As such, this capacitor must be periodically re-charged from the V_{BIAS} supply. The time t_{prg} is the minimum time required to ensure that the bootstrap capacitor is properly charged when power is initially applied to the EPC7012L7SH IC.
- 14) The minimum frequency of operation is determined by the external bootstrap capacitance and the bias current required by the high-side power switch gate driver circuit, I_{BOOT} . In order to keep the high-side power switch gate driver bootstrap capacitor properly charged on a cycle-by-cycle basis, it is recommended that the maximum duty cycle of the high-side power switch is limited to the value shown.
- 15) See radiation report for details.

Switching Figures

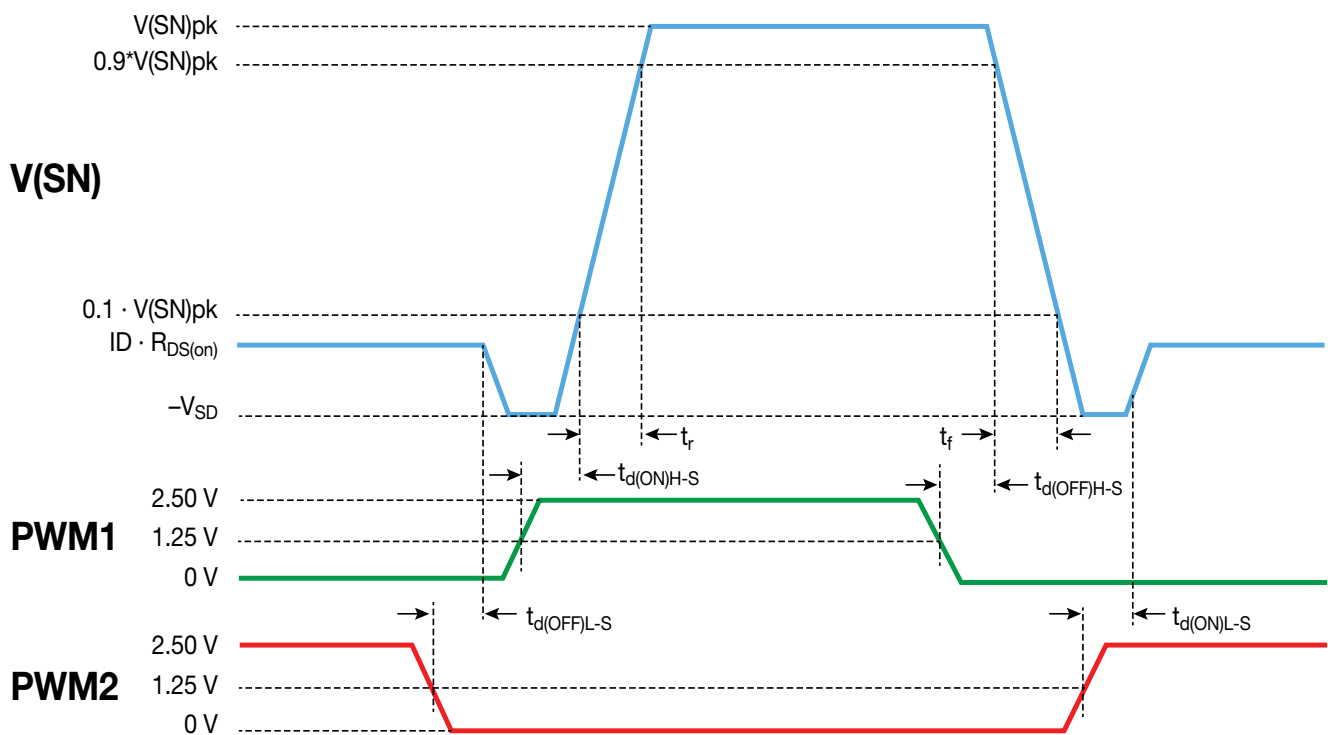
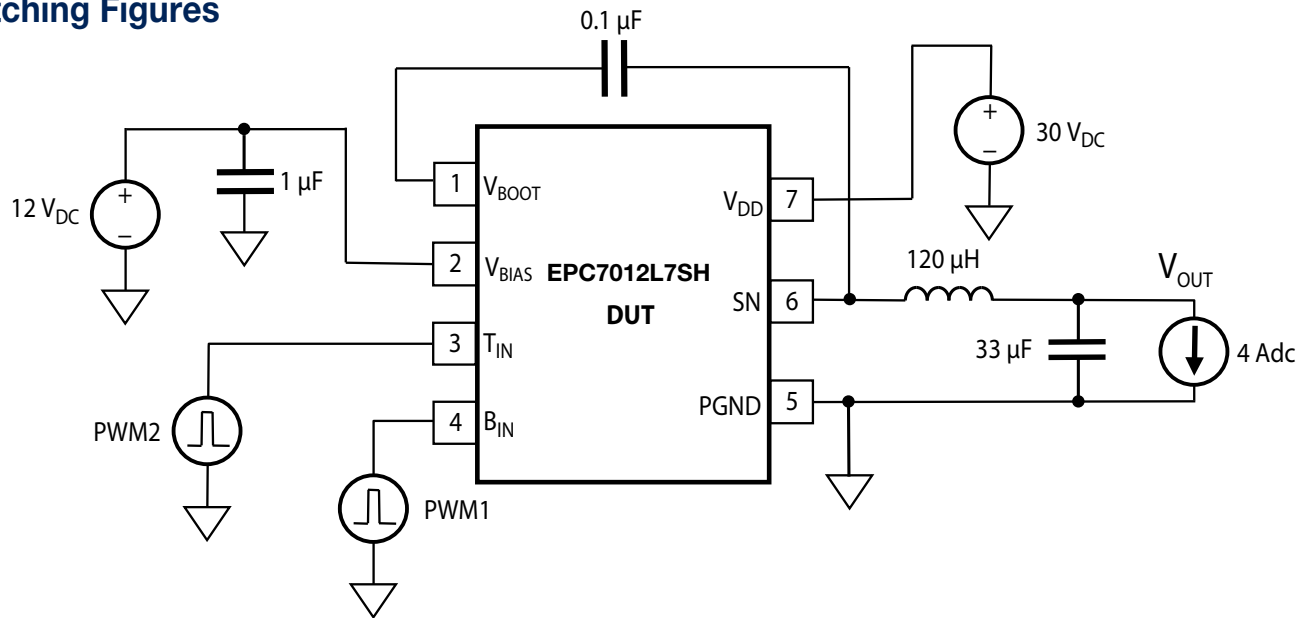

Figure 1. Switching Figures

B_{IN}	T_{IN}	LS	HS
0	0	Off	Off
1	0	On	Off
0	1	Off	On
1	1	Off	Off

Logic input Shoot-Through Protection

The EPC7012L7SH is provided with input shoot-through (cross-conduction) protection such that if the B_{IN} and T_{IN} logic inputs are asserted as logic state high (“1”) simultaneously then the switching node (SN) assumes a high impedance (hi-Z) state until one of the logic inputs is asserted to a logic low (“0”) state. This feature prevents the EPC7012L7SH IC from being destroyed by an unintentional illegal logic condition at the logic inputs.

High-Side Bootstrap Capacitor Periodic Recharge

The high-side power switch gate driver utilizes a bootstrap capacitor to provide the proper bias for this circuit during switching operation. As such, this capacitor must be periodically recharged from the V_{BIAS} power supply. The time t_{prg} is the minimum time required for the low-side driver to be turned ON in order to ensure that the bootstrap capacitor is properly charged when power is initially applied to the EPC7012L7SH IC.

Power-Up Sequencing

There are no power sequencing requirements for the V_{BIAS} and V_{DD} power supplies required by the EPC7012L7SH. The two power supplies may be applied to the IC in any order/sequence required by the end-user.

Schottky “Catch” Diodes

If third-quadrant operation of the internal output HEMTs in the EPC7012L7SH is not desired, then it is recommended that two external Schottky “catch” diodes (Dext1 and Dext2) be added between V_{DD} and SN and between SN and PGND as shown in Figure 2. The diodes should be properly de-rated for both voltage and current.

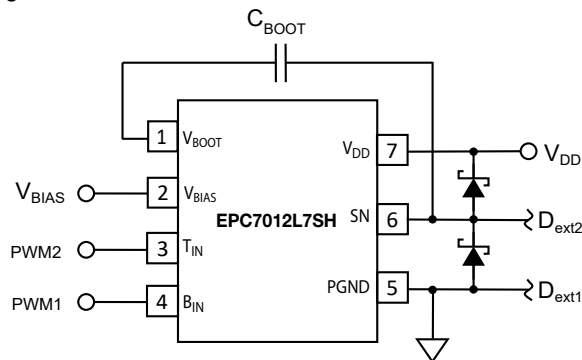

Figure 2. External Schottky Catch Diode Connections

Place the diode packages as physically close to the EPC7012L7SH package as possible, and keep the connections as short as possible, to eliminate parasitic loop inductances.

“Slow-Down” Resistors

The EPC7012L7SH is designed to be a high-speed power driver. As such it has extremely fast switching node (SN) rise and fall times by design. Fast rise and fall times can and will result in unwanted voltage spikes at the V_{DD} and PGND pins due to any parasitic layout inductance ($V_{SPIKE} = L_{Par} \cdot di / dt$). If as a result of the optimized PCB layout that these spikes cannot be reduced to an acceptable level, it is recommended that two resistors be added to the circuit to decrease the slew rates of the low- and high-side gate drive signals, which in turn decreases the slew rates of the switching node rise and fall times. These resistors, R_{SD1} and R_{SD2} are shown in Figure 3.

R_{SD1} increases the fall time of the SN, as it affects the low side driver. Similarly, R_{SD2} increases the SN rise time. It is recommended that the maximum value of either R_{SD1} or R_{SD2} is 15 Ω to ensure proper switching operation of the EPC7012L7SH.

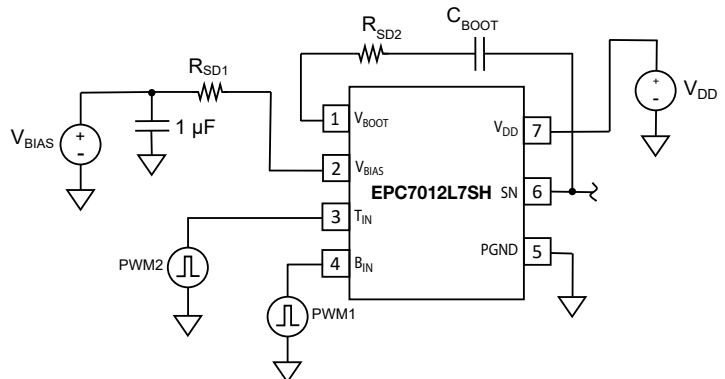

Figure 3. External Slow-Down Resistor Connections

Recommended V_{DD} -to-PGND Power Supply Bypassing

The V_{DD} power supply pin and the return pin of the EPC7012L7SH require proper high frequency bypassing to one-another in order to prevent harmful switching-related spikes from degrading or damaging the internal circuitry in the IC. Depending upon the PCB layout, this situation may be true even if slow-down resistors are employed.

Because of the extremely high rate-of change of voltage seen at the SN output it is recommended that a minimum of one (1) 3.3 μF microfarad ceramic capacitors, one (1) 1.0 microfarad ceramic capacitor, one (1) 0.1 microfarad ceramic capacitor and one (1) 0.01 microfarad ceramic capacitor, all with sufficient voltage de-rating, be connected from V_{DD} to PGND. All four of these capacitors should be low ESR types, if possible. It is strongly recommended that these capacitors have the smallest possible case sizes possible such that they inscribe the smallest possible loop area between V_{DD} and PGND so as to minimize the inductance related to this loop area. Also, to reduce the inductive loop between V_{DD} and PGND is strongly recommended that an induction loop cancellation layout of the high frequency power supply capacitors be employed. Figure 4 illustrates the recommended optimum layout and placement for the V_{DD} -PGND high-frequency bypass capacitors.

It should be noted that in Figure 4 that the light green copper etch area on the PCB's inner layer #1 is positioned directly beneath the copper etch clad on the top layer, as indicated by the dashed line.

The recommended component placement and etch layout capitalize upon the magnetic field/flux cancellation between adjacent current carrying layers on the PCB. The high-frequency AC current (shown in RED in the side view) drawn from the V_{DD} power bus through the EPC7012L7SH IC is then returned through the adjacent PCB copper etch layer 180 degrees out of phase with the top layer PCB etch to create the cancellation. The result is a very small residual parasitic loop inductance, and an associated lower spike voltage present on the V_{DD} and PGND pins of the IC.

The requirements of each PCB implementation of the EPC7012L7SH may not allow the recommended optimum layout shown in Figure 4 to be implemented, but care should be taken to keep the recommended layout as physically and mechanically close to it as possible.

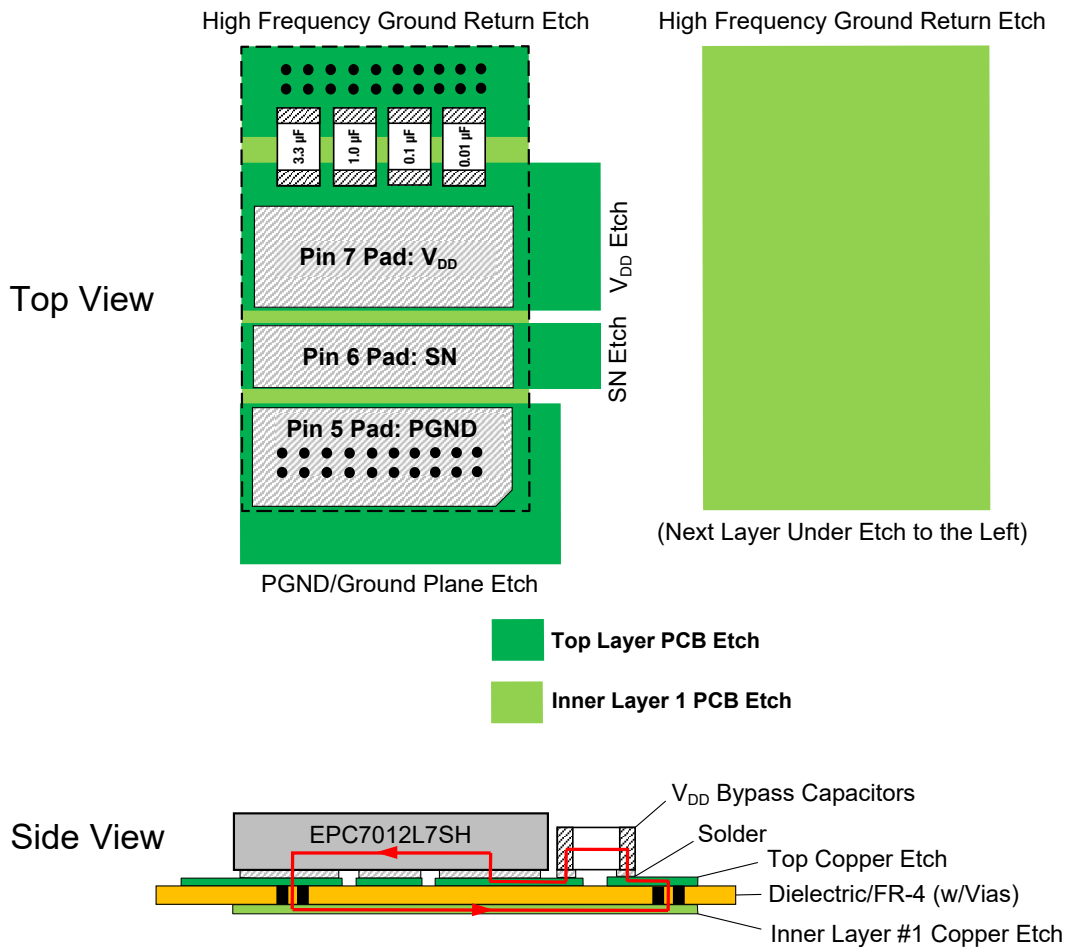

Figure 4. Recommended Optimum V_{DD} -to-PGND Power Supply Bypass Capacitor Layout (Not to Scale)

Suggested EPC7012L7SH Schematic Symbol

The suggested schematic symbol for the EPC7012L7SH is shown in Figure 5.

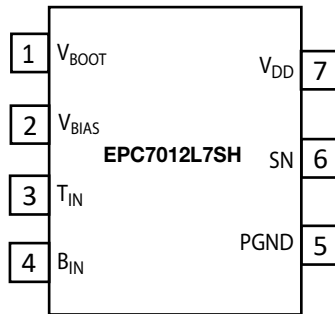
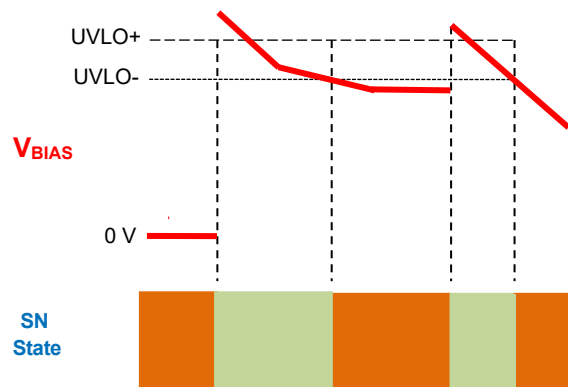

Figure 5. Suggested EPC7012L7SH Integrated Circuit Schematic Symbol

Under-Voltage Lock-Out Behavior



Waveforms exaggerated for clarity and observability.

NOTE A: SN follows B_{IN} Input: Hi-Z for $B_{IN} = "0"$ and PGND for $B_{IN} = "1"$. In both cases $T_{IN} = "0"$.

Figure 6. V_{BIAS} UVLO-to-SN Relationship

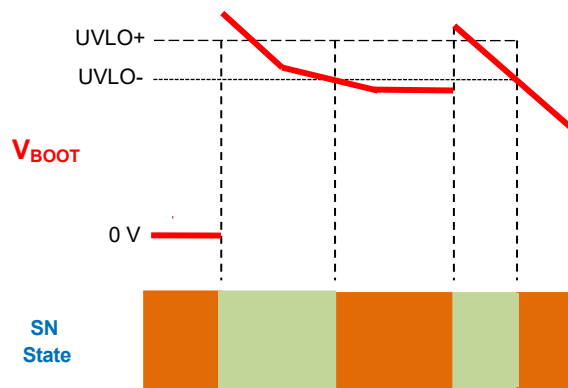

Waveforms exaggerated for clarity and observability.

NOTE B: SN follows T_{IN} Input: Hi-Z for $T_{IN} = "0"$ and V_{DD} for $T_{IN} = "1"$. In both cases $B_{IN} = "0"$.

Figure 7. V_{BOOT} UVLO-to-SN Relationship

Typical Application Information

The following figures detail the suggested applications for the EPC7012L7SH Module. For all applications, please refer to the Implementation section, following, for proper power supply bypassing and layout recommendations and criteria. In any of the following applications, if an inductive load is driven then an appropriately-rated Schottky rectifier/diode should be connected across the load to prevent destructive flyback/“kickback” voltages from destroying the EPC7012L7SH.

In all the following figures only the pins that are considered or that require connection are identified.

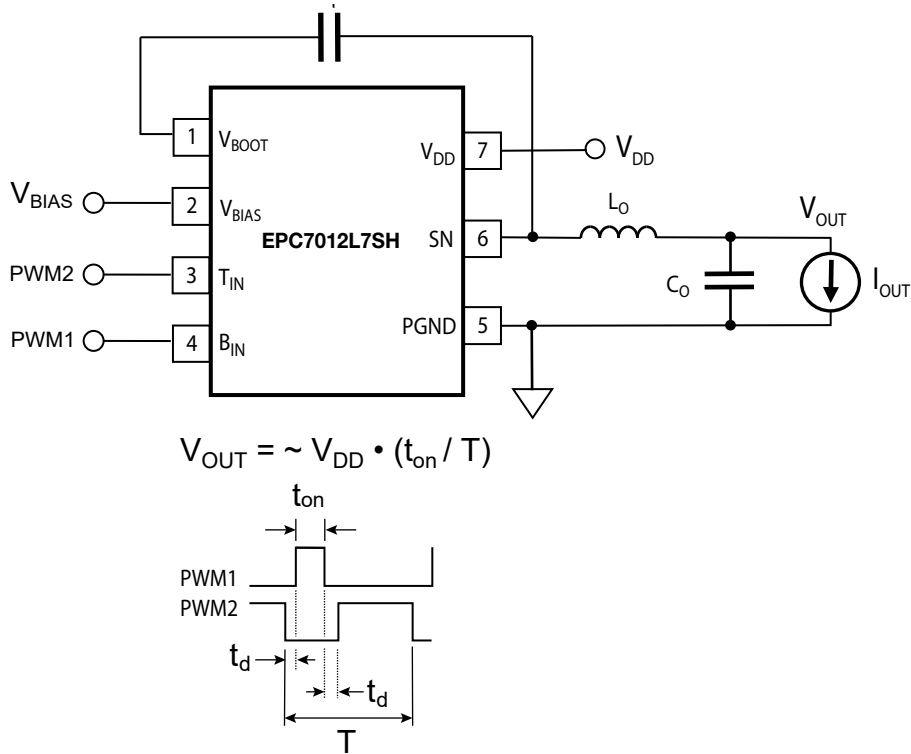

Figure 8. Low Parts-Count POL Converter Power Output Stage

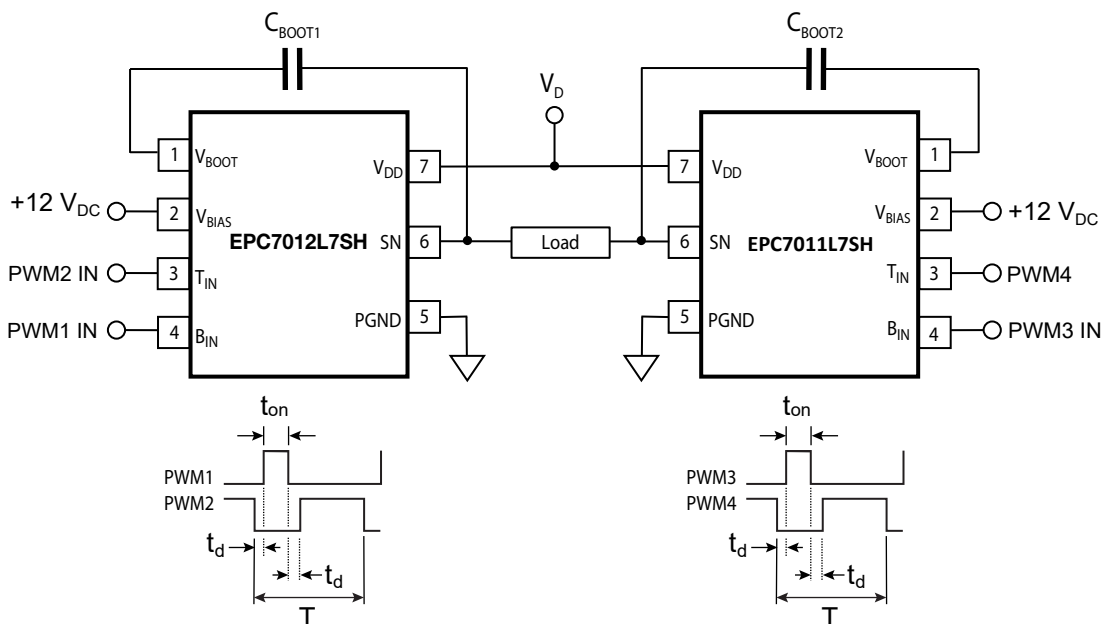

Figure 9. Bridge (Class D) Amplifier Power Output Stage.

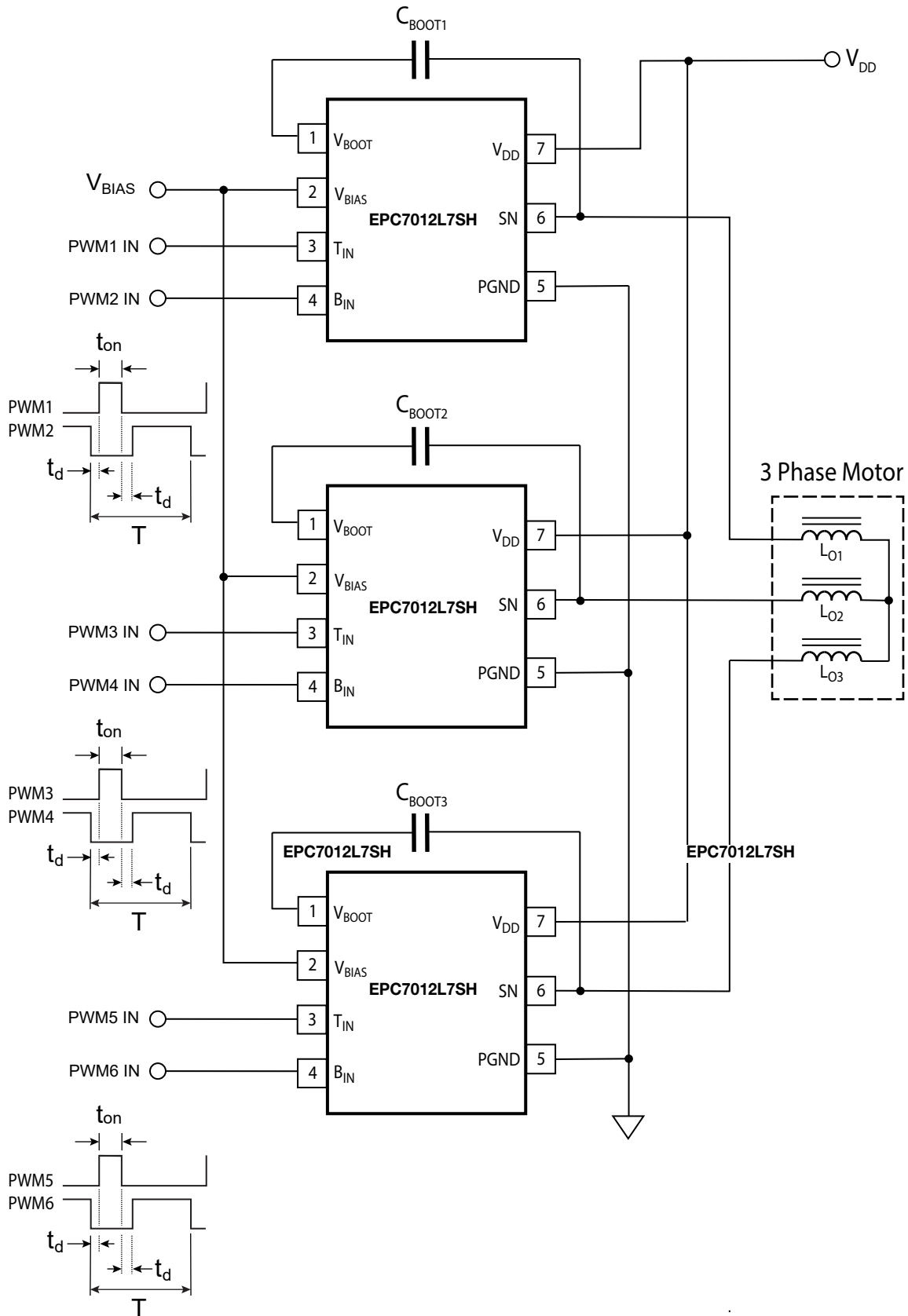

Figure 10. Low Parts-Count Three Phase Motor Drive Stage

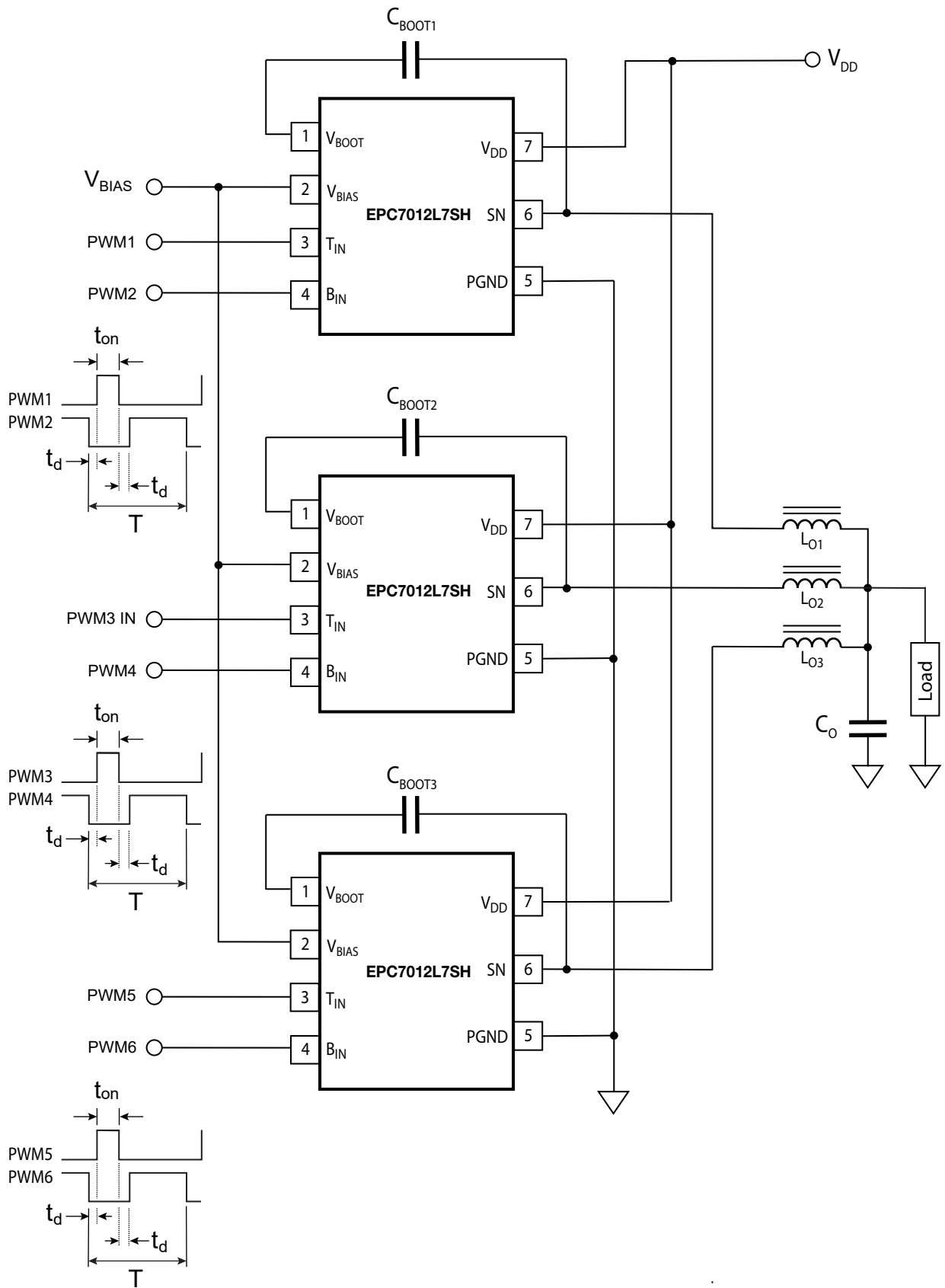

Figure 11. Three-Phase Interleaved POL Converter

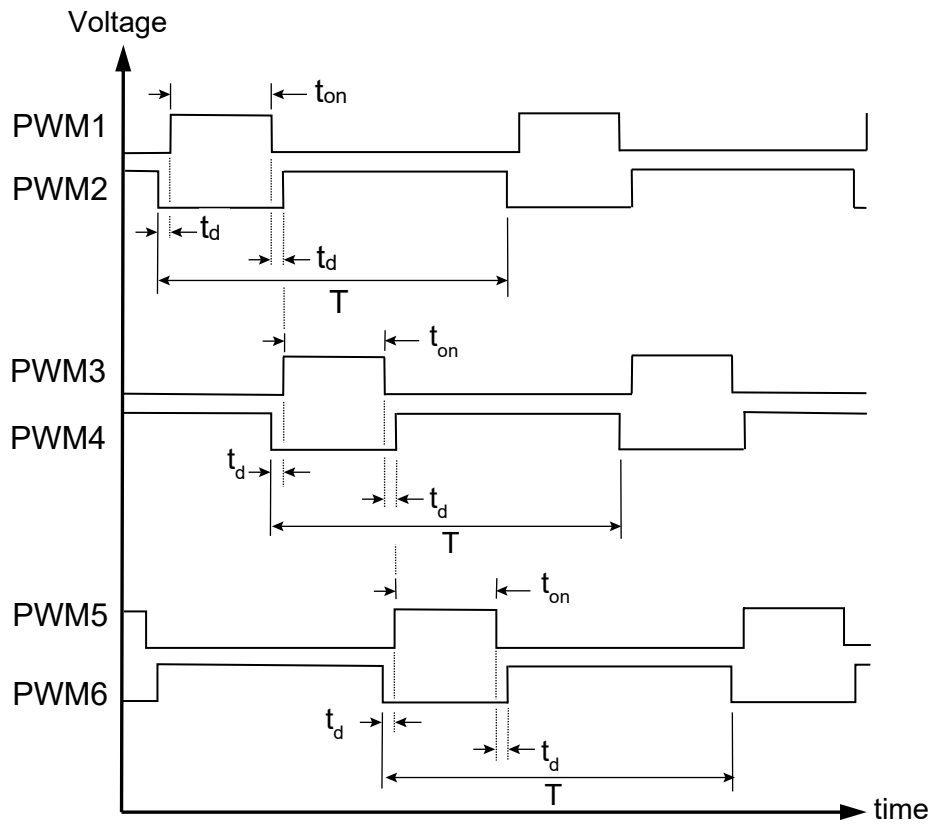
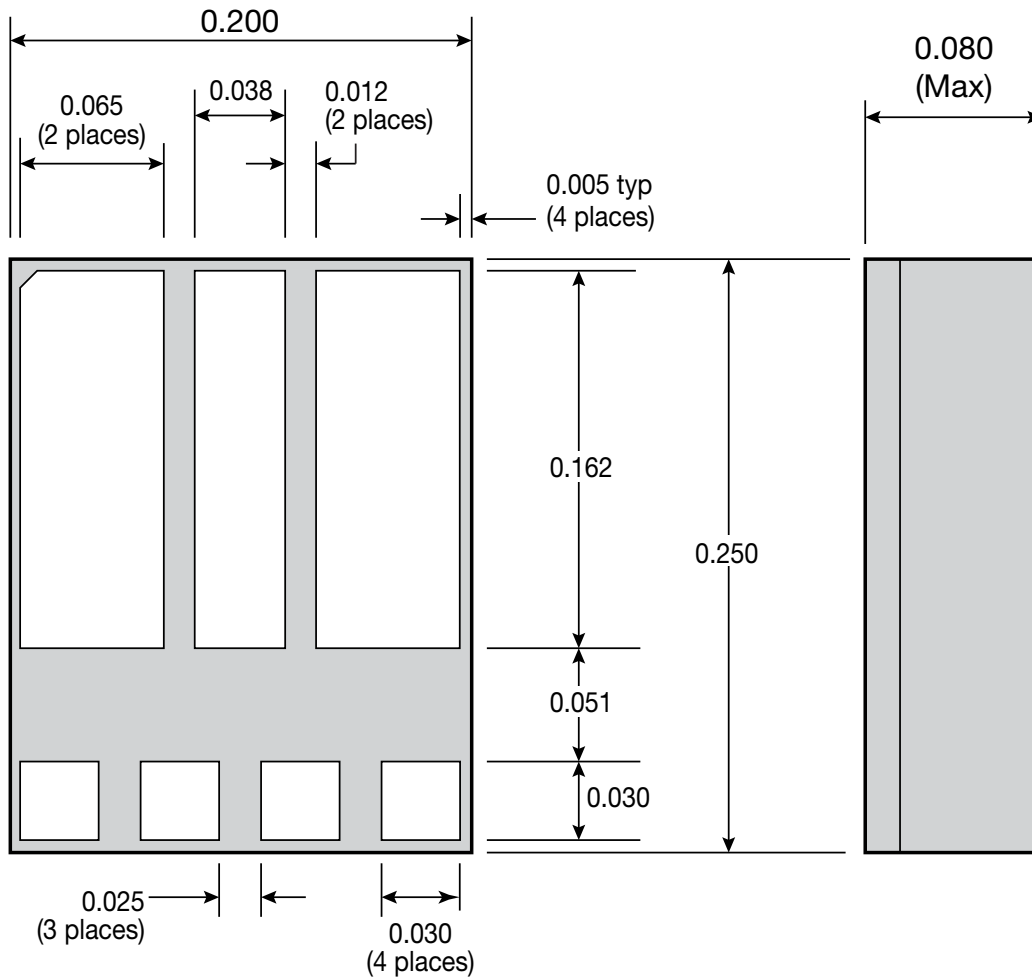

Figure 12. PWM Timing for Figure 11

In an interleaved configuration the EPC7012L7SH IC's share the load current during their ON times. The ON times of the paralleled converters are phase shifted in time by $360/N$, where N is the number of converters in parallel. For example, if two converters are paralleled, the phase shift is 180 degrees, and for three the phase shift is 120 degrees.

This configuration allows each EPC7012L7SH to provide its full rated current of 6A to the load for a total load current of 18 A.

Package Outline and Dimensions



Note: All dimensions are in inches
ALL tolerances +/- 0.005

Figure 13. EPC7012L7SH Package Outline and Dimensions

Recommended PCB Solder Pad Configuration

It is important that the EPC7012L7SH package be soldered to the PCB motherboard using SN63 (or equivalent) solder. Care should be taken during processing to insure there is minimal solder voiding in the contacts to the V_{DD} (pin 7), SN (pin 6) and PGND (Pin 5) pads on the package. The recommended pad dimensions and locations are shown in Figure 14. All dimensions are shown in inches.

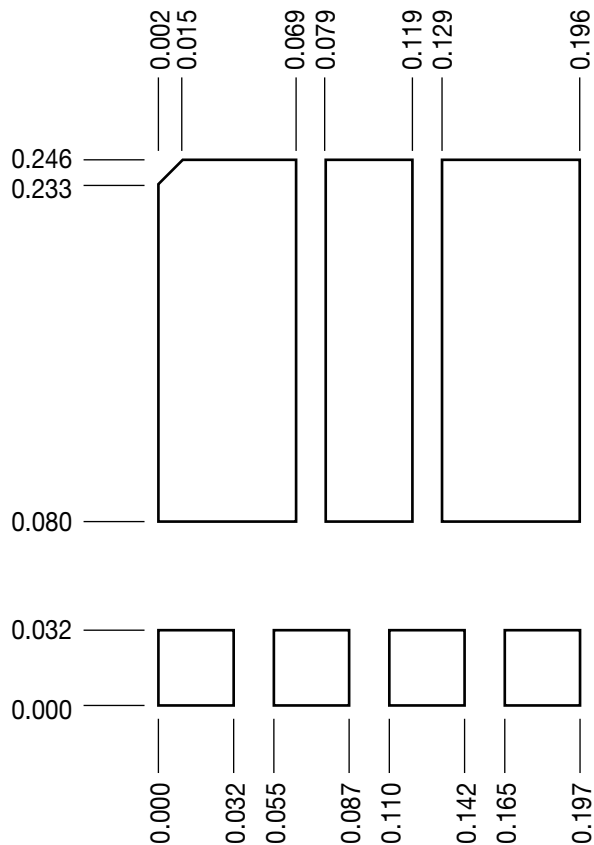

Figure 14. Recommended PCB Solder Pad Configuration (Top View)

Example Typical Reflow Profile

The profile shown in Figure 15, below, is a typical reflow profile example. The end user must optimize target reflow temperature profiling based against the actual solder paste used. **The peak case temperature should never be allowed to exceed 225°C.**

Temperatures in excess of this limit can permanently damage the device.

EPC Space assumes no liability in conjunction with the use of this profile information.

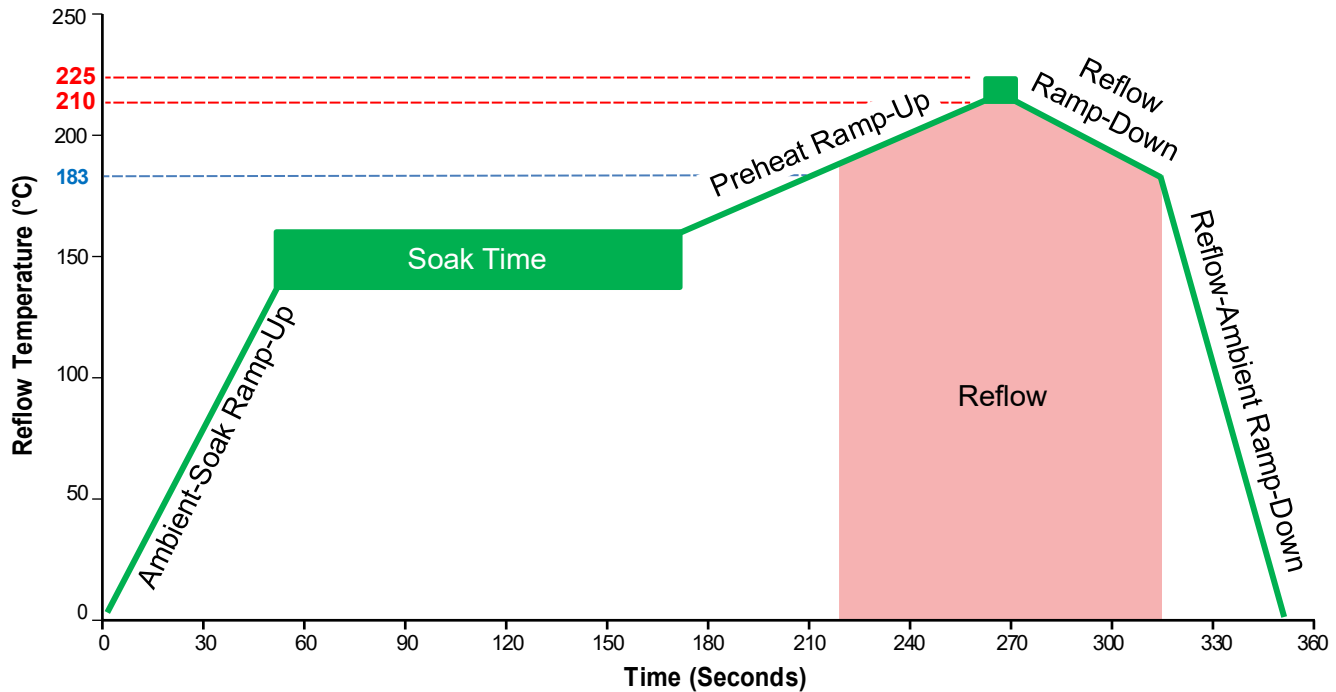

Figure 15. Typical EPC7012L7SH Package SN63/37 Solder Attachment Reflow Profile

Typical Reflow Parameters:

Ambient-to-Soak Ramp-Up Rate: 2.5°C per second, maximum.

Soak Time: 30 to 120 seconds.

Soak Temperature: 140°C, minimum to 160°C, maximum.

Preheat Time: 120 to 270 seconds, typical.

Preheat Ramp Rate: 0.5°C per second, typical.

Reflow Time (above 183°C): 60 to 90 seconds.

Peak Reflow Temperature: 210°C, minimum to 225°C, maximum.

Peak Reflow Duration: 20 seconds, maximum at peak reflow.

Preheat Ramp-Down Rate: 0.5°C per second, typical.

Reflow-Ambient Ramp-Down Rate: 3.5°C per second, minimum to 5.0°C per second, maximum.

Ordering Information Availability

Part Number	Screening Level	Radiation Level	Shipping
EPC7012L7SH	Space	1000 kRad LET = 63	Tape and Reel Waffle Pack

Disclaimers

ALL PRODUCT, PRODUCT SPECIFICATIONS AND DATA ARE SUBJECT TO CHANGE WITHOUT NOTICE TO IMPROVE RELIABILITY, FUNCTION OR DESIGN OR OTHERWISE. EPC Space Corporation, its affiliates, agents, employees, and all persons acting on its or their behalf (collectively, "EPC Space"), disclaim any and all liability for any errors, inaccuracies or incompleteness contained in any datasheet or in any other disclosure relating to any product. EPC Space makes no warranty, representation or guarantee regarding the suitability of the products for any particular purpose. To the maximum extent permitted by applicable law, EPC Space disclaims (i) any and all liability arising out of the application or use of any product, (ii) any and all liability, including without limitation special, consequential or incidental damages, and (iii) any and all implied warranties, including warranties of fitness for particular purpose, non-infringement and merchantability. Statements regarding the suitability of products for certain types of applications are based on EPC Space market knowledge of typical requirements that are often placed on similar technologies in generic applications. Product specifications do not expand or otherwise modify EPC Space terms and conditions of purchase, including but not limited to the warranty expressed therein. Except as expressly indicated in writing, EPC Space products are not designed for use in medical, life-saving, or life-sustaining applications or for any other application in which the failure of the EPC Space product could result in personal injury or death. Customers using EPC Space products not expressly indicated for use in such applications do so at their own risk. Please contact authorized EPC Space personnel to obtain written terms and conditions regarding products designed for such applications. No license, express or implied, by estoppel or otherwise, to any intellectual property rights is granted by this document or by any conduct of EPC Space. Product names and markings noted herein may be trademarks of their respective owners.

Export Administration Regulations (EAR)

The products described in this datasheet are subject to the U.S. Export Administration Regulations (EAR), 15 C.F.R. Pts 730-774, and are classified in ECCN 9A515.e. These products may not be exported, reexported, or transferred (in country) to any foreign country, or foreign entity, by any means, except in accordance with the requirements of such regulations.

Patents

EPC Corporation and EPC Space hold numerous worldwide patents. Any that apply to the product(s) listed in this document are identified by markings on the product(s) or on internal components of the product(s) in accordance with local patent laws.

eGaN® is a registered trademark of Efficient Power Conversion Corporation, Inc. Data and specification subject to change without notice.